



mounting
systems



Set No.
720-1734

Ref-No.
805-0051

Roof Hook Stainless Steel 150-9-49 Heavy Load

Roof cladding	Pitched - with roof tiles
Material	Stainless steel A2
Total height	228 mm
Height in roof batten area (a)	49 mm
Max. height adjustance (b)	30 mm to rail area
Drilling base plate	7 x \varnothing 9 mm
Weight	1.30 kg

Dimensions

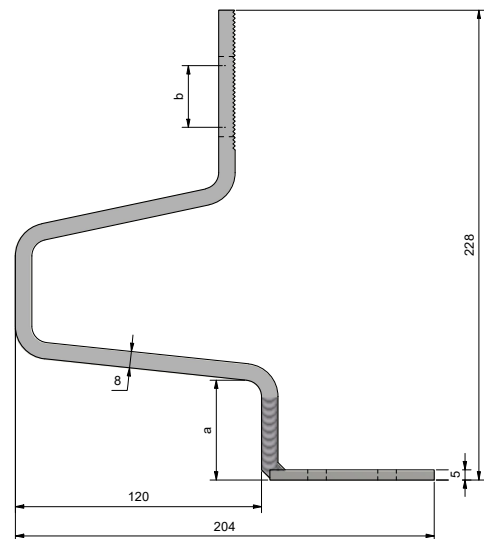
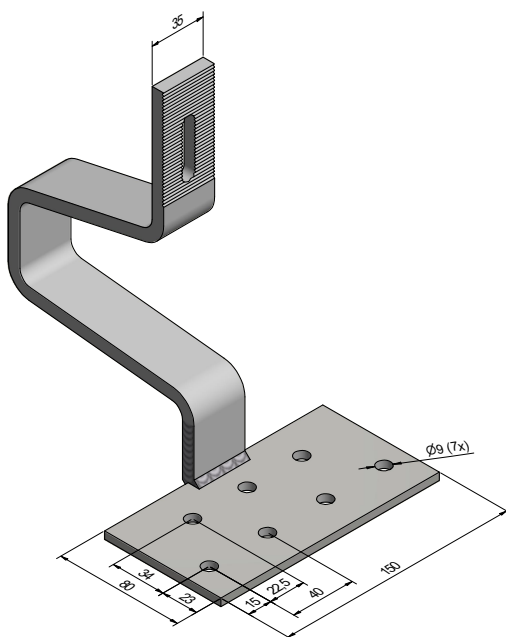

Technical amendments reserved.
2024 © Mounting Systems GmbH