



User Manual

Lithium Iron Phosphate (LiFePO₄) Rechargeable Battery



PLEASE KEEP THIS MANUAL FOR FUTURE REFERENCE

1 Product Introduction

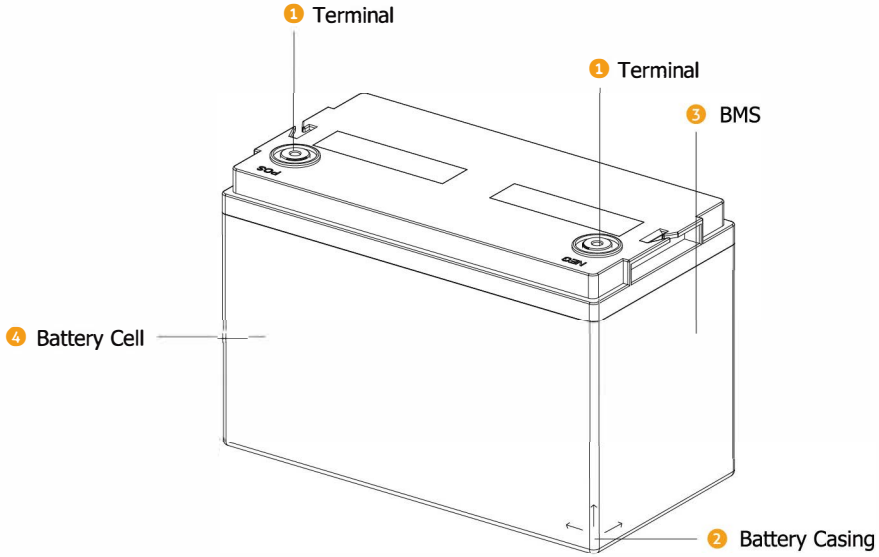

Description

No.	Item	Description
1	Terminal	Charge and discharge wiring port, M8 threaded hole, can directly replace lead-acid battery application.
2	Battery Casing	Compliant to BCI Dimensions.
3	BMS	Built-in BMS, with overcharge, over discharge, over current, over temperature, short circuit and other protection functions; support operation in series (maximum up to 48V). Please refer to "Instruction for Connecting in Series and Parallel" for more details.
4	Battery Cell	With pouch lithium-ion battery built in, which has the advantages of high specific energy, high safety, long life, low internal resistance, low weight and low self-discharge.

Specifications

MODEL	CAPACITY (Ah)	CHARGE CURRENT (A)	MAX CHARGE CURRENT (A)	MAX DISCHARGE CURRENT (A)	PULSE CURRENT (A) (< 3S)	DIMENSIONS (MM)	TERMINAL
12V10Ah	10	2	10	10	20	151*100*104	F2
12V20Ah	20	4	20	20	40	181*77*170	M5
12V33Ah	33	6.6	33	33	66	196*132*166	M6
12V40Ah	40	8	40	40	80	196*166*169	M6
12V75Ah	75	15	75	75	200	260*168*212	M6
12V100Ah	100	20	100	100	350	327*172*218	M8

- These batteries are mainly used in RV, utility trucks, emergency vehicles, yacht, golf cart, solar street light, UPS, emergency lighting, alarm system, photovoltaic energy storage, 48V low speed vehicle and other types of deep cycle lead-acid battery replacement.
- Battery needs to be operated under:
 - * Acceptable ambient operating temperature: charging at 0°C~45°C, and discharging at -20°C~55°C
 - * Charging voltage is 14.4V
 - * Ambient humidity: ≤85%

⚠ Cautions: Improper use will cause irreversible damage to the battery, and could cause battery swelling and smoke in extreme cases.

Installation Instruction

Please follow the vehicle/equipment manufacturer's instructions:

- When replacing various types of deep cycle applications, please ensure the battery capacity is not less than the original lead-acid battery.
- Please check the battery status before installation:
 - * Please check the battery voltage with a multimeter. If the battery voltage is less than 13V, please recharge it (Refer to "Charging Instruction").
 - * When connecting in series or in parallel, please ensure the capacity and voltage between each battery is consistent (Refer to "Instruction for Connecting in Series and Parallel").
 - * Please check the battery to ensure the terminals are clean with no rust, and the screws are clean without foreign objects.
 - * Please ensure that the cable connecting the battery terminals is long enough.
 - * Please ensure that the screws on the terminals are fixed/tightened to the maximum to avoid loosening during operation.
 - * Please ensure that the maximum output voltage of the charging device connected to the battery does not exceed 14.6V before connecting.

Charging Instruction

- Please ensure charging voltage is 14.4V.
- The charging current must not exceed the maximum charging current which is indicated in the specification sheet in this User Manual.
- The batteries used in series do not need to be disassembled for separate charging, but ensure that the individual batteries must be fully charged before connecting in series. For details, please see "Instruction for Connecting in Series and Parallel".
- Please ensure to charge at an ambient temperature of 0°C~45°C. Below 0°C or above 45°C may cause irreversible damage to the battery or even a safety risk.
- You must NOT use a lead-acid battery charger if it has any following mode or function:
 - "Equalization mode"
 - "Desulfation mode"
 - "Pulse function"

-
- DO NOT leave the lead-acid battery charger connected to maintain or store the battery, because most will NOT maintain the proper voltage charge algorithm for lithium batteries and damage will occur to the battery.
 - If you want to charge a battery with lead-acid charging system, make sure the charging voltage is less than 14.6V. If charging batteries in series, make sure the charging voltage is less than 14.6V times the series number. For e.g., if you want to charge batteries in 4 series, the charging voltage should be less than 58.4V, and the charging current must follow the instruction.

Discharging Instruction

- Please do not exceed the maximum discharge current in this User Manual.
- Do not discharge the battery with maximum discharge current several times in succession, since it may cause battery damage.
- The maximum continuous power for 12V100Ah, 12V150Ah, and 12V200Ah should not exceed 1280W. i.e., they can support 1000W inverter, but the maximum continuous load should not exceed 1100W (according to conversion efficiency 85%).
- Do not mix a new battery and a used battery in a same configuration.

Instruction for Connecting in Series and Parallel

- Please ensure to fully charge each battery before connecting in series or parallel.
- If the battery top cover has a label showing number 1-N, such as 1-1, 1-2, 1-3, 1-4, that means the batteries are grouped in manufacturing factory, to ensure the high consistence in case batteries would be connected in series or parallel. The first number is the group number, and the second number is the sequence within the group. Please do not mix different groups of batteries.
- The battery can be connected in series up to 4 batteries, or in parallel up to 2 batteries. Take 12V100Ah for e.g., 4 batteries connected in series can create a 48V100Ah battery bank; and 2 batteries connected in parallel can create a 12V200Ah battery bank.

- Parallel batteries can only increase the capacity of the battery system and increase the working time of the connected electrical devices. However, the maximum/peak discharge current can only be in accordance with a single battery. For e.g., use four 100Ah batteries configured in parallel to connect an inverter/motor or other devices, the maximum continuous power cannot be more than 1100W (according to conversion efficiency of 85%).

2 Warning and Attention

- Do not reverse the positive and negative of the battery.
- Do not touch or store the electrodes of the battery with unnecessary wires or other metal materials to avoid short circuit.
- Do not puncture, impact, drop, or step on the battery.
- Do not disassemble the battery or modify the outer casing.
- Do not expose the battery under the sun, since this may cause overheat, fire, or failure to the battery.
- Do not put the battery in a fire or heat the battery. Do not store the battery in a high temperature environment.
- Do not put the battery into the water, or in the rain for a long time. Battery should be stored in a cool and dry environment.
- If you detect any abnormal smell or noise while charge or discharge, remove the battery immediately and contact the dealer.
- When the battery is operated beyond the temperature range of 0°C~50°C, the capacity may decrease, this does not mean that the battery is damaged.

3 Trouble Shooting

No.	Symptom	Possible Causes	Corrective Actions
1	No DC output	Battery being protected by BMS	Check the circuits/working environment, and confirm the load power, to ensure the battery is being charged/discharged within the Max. charging/discharging current stated in the Specifications.

2	Battery working time is too short	The charging voltage is too low and the battery cannot be fully charged	Adjust the charging voltage at 14.4V.
		The load voltage is too high and the battery cannot be fully discharged	Reduce the load voltage or replace the battery with a larger capacity one.
		Over temperature	Lower down ambient temperature.
		Battery capacity becomes lower	Replace the battery.
3	Battery heat up	Over current	Reduce load power.
		Over temperature	Working within the operating temperature.
4	Spark occurs on cable terminals	Initial connect to capacitive load or inductive load	No action required.
		Power supply short circuit	Check the cause of the short circuit and disconnect it.

4 Storage & Transportation

Item		Criteria
Storage Temperature	Less than 1 month	-10°C~+45°C
	Less than 3 months	-10°C~+35°C
	More than 3 months	0°C~+30°C
Relative Humidity		≤75% RH
SOC		40%~60%

- To ensure a longer lifespan of the battery, please recharge it every 3-6 months.
- Please ensure the battery terminals and screw holes are clean and securely connected.
- If the load is in an unused situation for a long time, disconnect the battery from the load to prevent the battery/load from leakage and causing the battery to be over-discharged.
- Insulation and shockproof materials should be used for the outer packaging to avoid sudden collisions and squeezing during transportation.